

**Colfax**<sup>™</sup>



>> SCREW PUMPS WITH ALLSPEED CONTROLLER

**Maximum efficiency for  
meeting the highest standards.**

**EMTEC**<sup>®</sup>

High-performance  
screw pumps

- >> for emulsions
- >> for cutting and grinding oils
- >> for lubricant solutions
- >> up to 130 bar

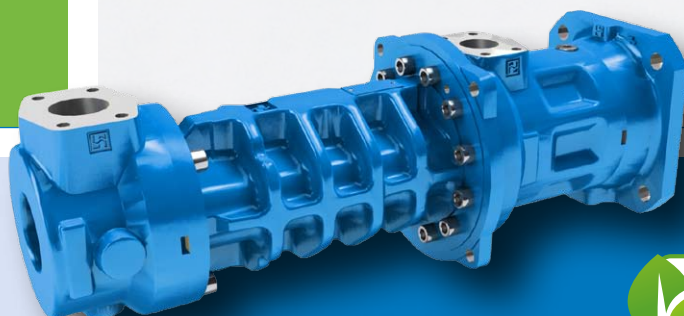

 **SAVING OF  
ENERGY COSTS**  
Up to 75%

## ALLWEILER AG. Cutting edge technology of the market leader.



Established in 1860, ALLWEILER has a long-standing tradition as a German manufacturer of pumps and is today the market and technology leader in the areas of ship-building, power generation and special industrial applications. Our product portfolio, which is unparalleled in this industry, includes centrifugal pumps, propeller pumps, screw pumps and eccentric screw pumps as well as complete pump systems. We also offer hose pumps and macerator pumps. In addition to our range of products, we also sell the products of our sister concern Zenith (gear pumps) and LSC (lubricating and oil regeneration systems).

### We offer solutions.

ALLWEILER customers can profit from our know-how, which has been acquired over generations. A very important factor for the success of our company is: While developing our ALLWEILER products, we put the customer requirements in the forefront. Our pumps are tailored exactly for the specific areas of application and feature good quality and reliability. Personal, competent on-site consultation and a comprehensive service round off our service pallet.

### Cost reduction through high-tech

We use state-of-the-art development and production methods and are experts for issues pertaining to material and sealings. Our aim is clearly defined: The best economic use of your ALLWEILER pump and thereby minimisation of the overall costs. Based on this philosophy, we develop first-class, innovative solutions, e.g. intelligent auxiliary modules for equipping your pump with specific Smart technologies. Faults that may lead to leakages, overheated bearings and defective sealings are identified at an early stage and can be eliminated immediately – a worthwhile advantage for substantially reducing the maintenance and life cycle costs.

**"If you are looking for economic efficiency in fluid handling, we are the experts."**

Stefan Werner  
Product manager ALLWEILER AG

### Successful all over the world.

The Colfax Corporation is one of the international industry leaders. As a part of this corporate group, we make use of the international sales structures and profit from the synergies and the transfer of know-how within the Colfax subsidiaries. Our presence worldwide is guaranteed through our establishments and affiliated companies.



## EMTEC® screw pumps. Technology that pays for itself everyday.

High-speed processing, minimum tolerances, short cycle times, maximum process security – the modern production technology puts forth extreme demands. This is where EMTEC® screw pumps offer a major advantage.

### Maximum service life.

The housing body is made from specially hardened grey cast iron (EN-GJL) and the housing surface is hard (like ceramic) in the contact area of the screw spindles. In practice, this means: As against systems made from other materials – such as SiC –, the EMTEC® is particularly insensitive to wear, shocks, gas loads or short-term reversion of rotation.

### The material that is used for the best.

The special material combinations of EMTEC® combine maximum possible hardness with optimum elasticity and fracture toughness.

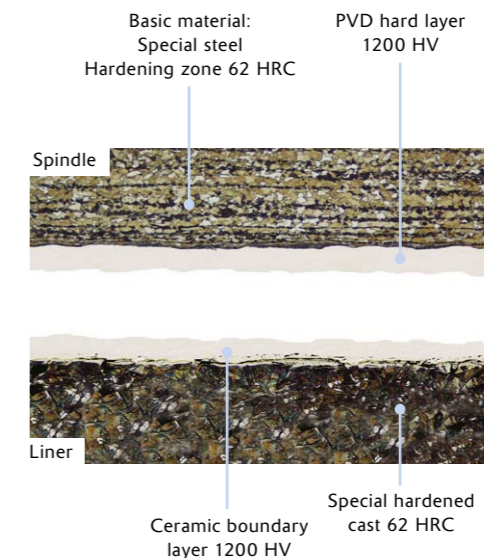

## Easy, cost-effective, space-saving: Installation as per your requirements.

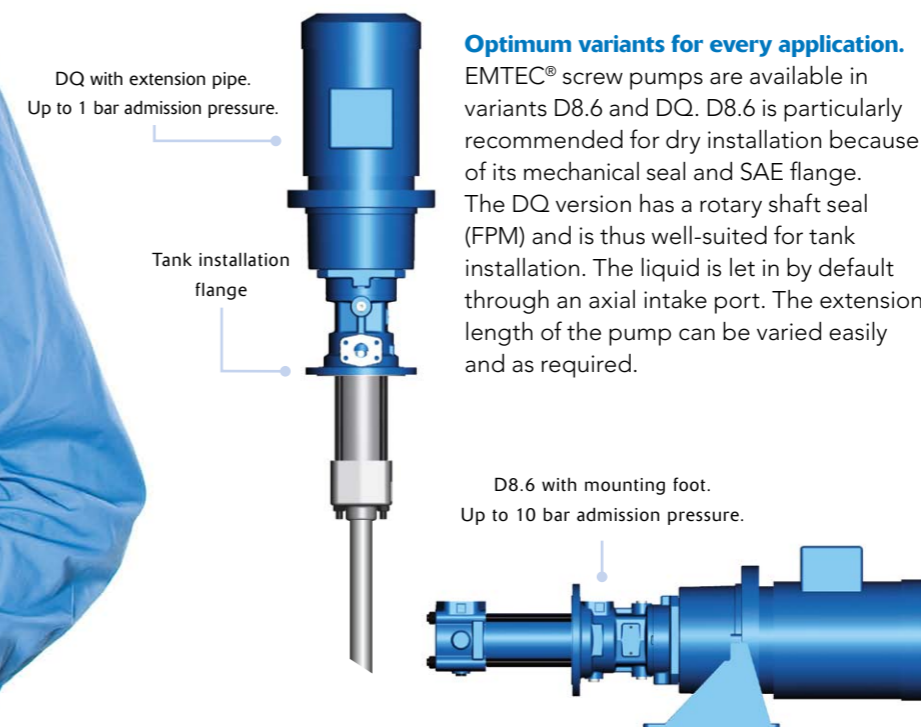

### Optimum variants for every application.

EMTEC® screw pumps are available in variants D8.6 and DQ. D8.6 is particularly recommended for dry installation because of its mechanical seal and SAE flange. The DQ version has a rotary shaft seal (FPM) and is thus well-suited for tank installation. The liquid is let in by default through an axial intake port. The extension length of the pump can be varied easily and as required.

### Comprehensive range of application

- EMTEC® is suitable for
- >> Machine tools of all kinds
- >> All lubricants
- >> Pressures ranging from 3 to 130 bar
- >> Flow rates from 0 to 1000 l/min

### Easy replacement in existing systems

You want to install EMTEC®, but your system is tailored to suit another pump and is already in operation. Do not worry: We have retrofitting kits ready, with which you can adapt EMTEC® quickly and easily to the existing installation dimensions.



### Dry installation

The dry installation with mounting foot is particularly maintenance-friendly and specially suitable for the operation with admission pressure. A silicon carbide mechanical seal guarantees high service life.

### Tank top mounting

Because of the tank mounting flange, EMTEC® can be easily installed with pressure pipe joints on the tank cover at reasonable costs.

### Submerged version

As against the dry version, the submerged version (tank installation) saves space, maintenance and costs. The leakage remains completely in the tank.

### Free installation

Any other horizontal or vertical position can be selected for the installation of EMTEC® (motor arrangement top).

# EMTEC® screw pump. Every detail is an advantage.

## High efficiency

>> More than 80% efficiency is achieved particularly while conveying cutting oils, even at high pressures. As compared to e.g. multi-staged centrifugal pumps, the required drive output reduces by up to 40%.

## Wide conveying range

>> Numerous pump sizes and spindle pitch angles; fine gradation of the flow rate over the entire output range.

### Safety

High impermeability of the connections through flanges according SAE. Alternatively, installation is also possible by pipe thread.

### Universal application

As against a centrifugal pump, EMTEC® has a broader pressure range with "rigid" flow parameters independent of the pressure increase.

### Minimisation of pulsation

Extremely low-frequency pulsing pressure of only 1 to 2% of the feed pressure: Uniform cooling efficiency, pulsation damper not required, no pipe fatigue.

### Ease of servicing

Service-friendly pump designs; simple assembly and easy to dismantle.

### Toughness

Complete, vibration-free, hydrostatic axial thrust compensation with special compensation bushes.

### High tolerance to contamination

External ball bearing, lubricated for life. Protected against getting washed out with a labyrinth seal.

### Resistance to wear

Long service life due to highly wear-resistant, specially hardened liner.

### Versatility

Variable assembly due to in-built tank mounting flange.

### Resistance to high pressure

Extra long pressure compensation piston with labyrinth seal.

### Durability

Higher pump service life due to highly wear-resistant PVD-coated spindles; minimisation of the surface load through long effector system.

### Zero Maintenance

Shaft seal in the D8.6 version with maintenance-free and highly wear-resistant silicon carbide mechanical seal in conformance with DIN EN 12 756.

### Maximum performance data

Flow rate	Q	up to 1,000 l/min
Pressure rise	$p_d$	up to 120 bar*
Supply pressure	$p_s$	up to 10 bar
Temperature	t	up to 80 °C
Viscosity	$\mu$	1 to 2,000 mm <sup>2</sup> /s
Degree of contam.		up to 250 mg/l
Degree of filtration		up to 100 $\mu$ m

\* Depending upon the pumped medium, speed and size

### Low sound power level

Sound power only 68 dBA at a speed of 2,900 1/min and 10 kW

# ALLSPEED Controller. Full performance at extremely reduced operating costs.

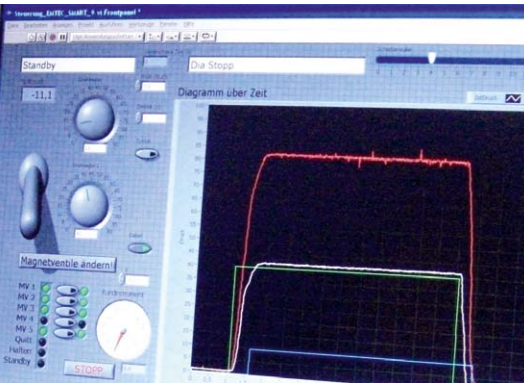

## More cost-effective and reliable without valves.

With ALLSPEED, a completely innovative controlling principle was implemented in practice for the first time: Adaptive flow rates and pressure control without valve control. The result is a clear reduction in the operating costs: Firstly, because no excess quantity can flow out without being used, thereby saving energy. Secondly, one can cut down on the control components,

apart from the valves; smaller cost-effective motors, pumps and coolers can be installed. Besides, ALLSPEED avoids pressure surges, which put load upon the seals and pipes and thereby lead to faults quite frequently, thus incurring major costs. Another plus point: The speed and pressure adjust precisely according to the different tools within a very short period of time without overshooting and without wave-like readjustment that takes several seconds.

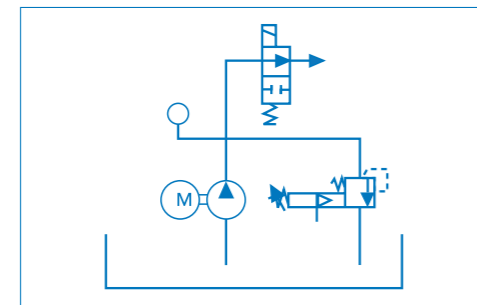

Conventional pressure control with valve  
Pump with a constant speed

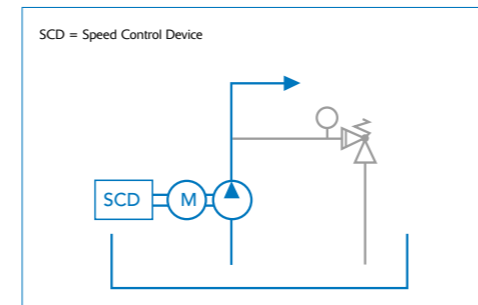

EMTEC® with ALLSPEED controller SCD  
The pump precisely delivers the required pressure and the required flow rate

## An intelligent speed control device, which reacts at lightning speed.

### Particularly dynamic under pressure.

Together with the ALLWEILER logic module, the ALLSPEED Controller SCD controls the motor of the EMTEC® pump at a highly dynamic level. Thus, speed steps can be realised of up to 5000 1/min and pressure

differences of up to 120 bar within only 500 ms. As a result, the exact pressure is always available and the desired coolant quantity is supplied under practically all operating conditions.

**ALLSPEED Controller SCD**  
Converter with in-built ALLWEILER logic module for the highly dynamic control of the EMTEC® pump motor

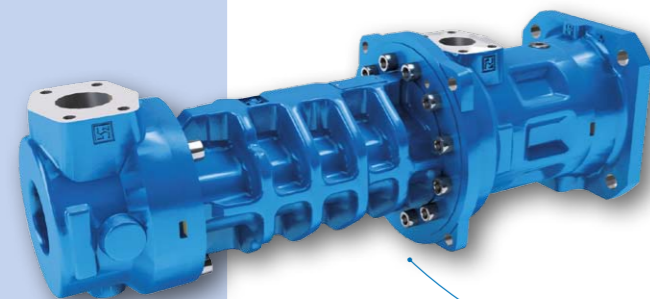

ALLWEILER logic module

EMTEC® + ALLSPEED Controller  
= 75 % saving of energy costs



# EMTEC® with ALLSPEED. The Dream Team for efficiency, safety and comfort.

### Can be used immediately.

ALLSPEED is a real plug-and-play solution, which does not involve the time-consuming programming and parameterisation prone to errors, which is a feature of conventional FU controls. In addition to this, it automatically adapts itself to every tool in an optimum manner.

### Broad speed range.

ALLSPEED can be used for a speed range up to 5,000 U/min. Thus, a single pump can cover a broader output range.

### In-built monitoring device.

The ALLWEILER ALLSPEED Controller reacts extremely quickly and precisely to parasitic inductions and deviations from the operating limits. This helps to prevent or minimise damages:

### >> Air in the system

If the ALLSPEED Controller detects air in the system, it adjusts the pump speed accordingly within a few milliseconds, thereby preventing pressure surges. The piping can be ventilated before the pressure generation via an auxiliary function.

### >> Motor overload

Here, the ALLSPEED control device reacts in two steps: First, the motor overload is tolerated for a short period of time. If the overload persists, ALLSPEED gives out an error message and automatically reduces the target pressure to the next optimum pressure-quantity combination within the permissible motor output. This correction also takes place when the speed is exceeding given limits.

### Independent and flexible coolant supply for every spindle.

Thanks to the high energy efficiency of ALLSPEED, the supply of every spindle through a separate pump is profitable. The benefits: Ideal pressure for every tool, lesser machining time, optimised surfaces, longer tool service life.

### Maintenance of pressure at zero delivery.

Can be manually enabled in the event of a zero delivery: The maintenance of static pressure when the pipeline is closed.

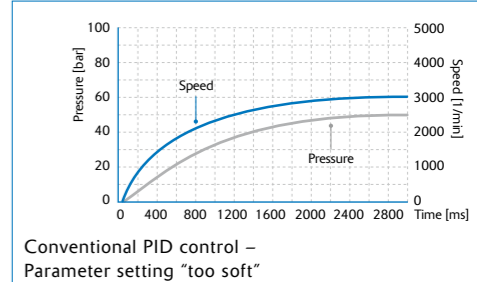

Conventional PID control –  
Parameter setting "too soft"

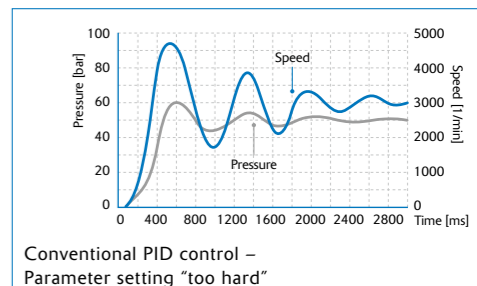

Conventional PID control –  
Parameter setting "too hard"

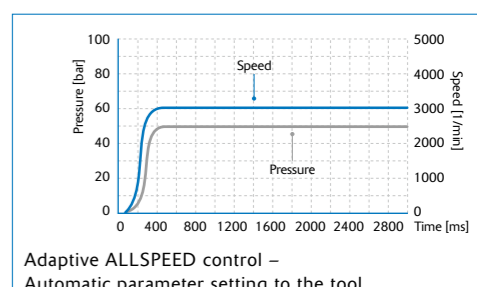

Adaptive ALLSPEED control –  
Automatic parameter setting to the tool

### Reduced energy consumption with the example of different operating points

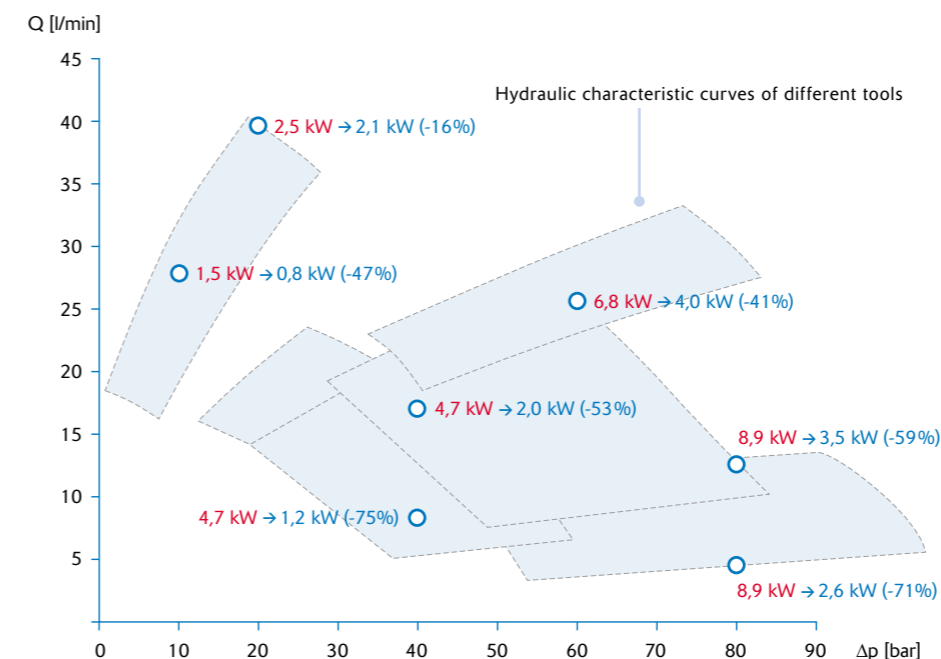

Red values: Energy/power requirement EMTEC®-A 40R38 with 11 kW motor without ALLSPEED Controller  
Blue values: Energy/power requirement EMTEC®-A 20R38 with 4 kW motor with ALLSPEED Controller

### You get your money's worth.

With EMTEC® pumps + ALLSPEED speed control, you can reduce the power costs by an average of 50%. At an average 5 kW consumption during 8,000 operating hours per year, you can save energy costs worth 2,000 Euro in one operating year (Basis: 10 ct/kWh)!

**2,000 Euro saving during  
one operating year**

# EMTEC® Global Service. We are at your service. Promptly and everywhere.

Our experienced specialists are available wherever you need us – during the day and also at night. Wherever your machine tool equipped with an EMTEC® pump is located, you will receive service and support from us within 24 hours. Thus, you can dispense with the expensive storage of spare parts and also profit from the optimum utilisation of your system.



- EMTEC® Global Service Centre
- Colfax/ALLWEILER production centres
- Colfax/ALLWEILER sales and service support stations

## ALLWEILER AG EMTEC Global Service

- >> **America**  
**24h-Hotline**  
+1 (704) 289-6511  
[emtec.america@colfaxcorp.com](mailto:emtec.america@colfaxcorp.com)
- >> **Europe, Middle East and Africa**  
**24h-Hotline**  
+49 (0)7732 86-886  
[emtec.europe@allweiler.de](mailto:emtec.europe@allweiler.de)
- >> **Asia**  
**24h-Hotline**  
+86 (510) 8520-2211  
[emtec.asia@colfaxcorp.com.cn](mailto:emtec.asia@colfaxcorp.com.cn)



ALLWEILER is a business unit of Colfax Corporation

## ALLWEILER AG

Allweilerstraße 1  
78315 Radolfzell  
Germany

Tel.: +49 (0)7732 86-0  
Fax.: +49 (0)7732 86-436  
[service@allweiler.de](mailto:service@allweiler.de)

[www.allweiler.com](http://www.allweiler.com)